

SB / SBR / SBN

Vertical agitators



Within the wide range of vertical agitators, INOXMIM has developed SB, SBR and SBN portable agitators to provide a high level of agitating in small volume vessels. Thanks to their compact design and simple clamp anchoring system, they are ideal for agitating open vessels, dispersing reagents and powders, and maintaining mixes. The bolstering tower extends the working life of the motor, increasing its resistance and allowing a longer shaft length.

The agitator fitted in these models means they can be widely used in the water treatment, chemical, food, pharmaceutical and cosmetics industries. Moreover, the semi-shaft transmission system facilitates the interchangeability of agitator elements whenever different vessels and/or applications are used. The result is a high degree of sanitisation.

CHARACTERISTICS

- MARINE propeller
- Anchor clamp
- Bolstering tower
- Lip seal
- Easy assembly/dismounting
- Interchangeability of agitator components
- Lightweight portable unit
- Direct motor (SB) / Geared motor (SBR)

MATERIALS

- Shaft/propeller material SS AISI 316
- Turret material: Cast aluminium

OPTIONS

- Control panel
- Pneumatic motor (SBN agitator)
- Propeller and shaft cover (PVC, PE or resin)
- Other types of propeller

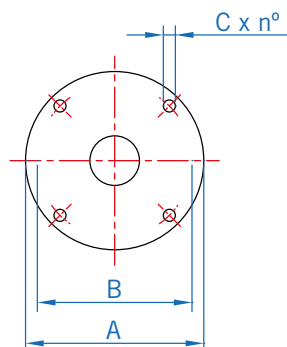
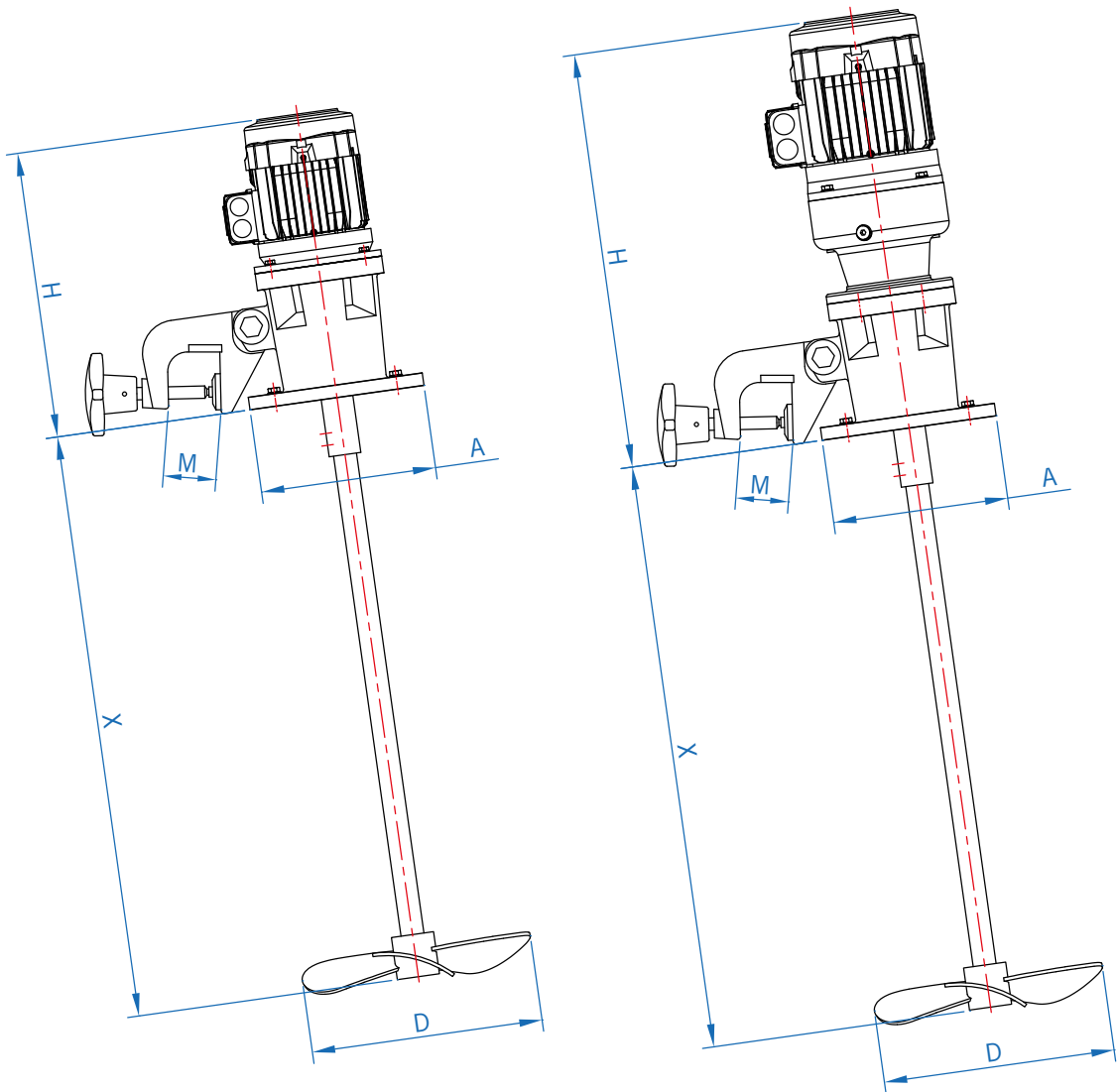

DN 50 FLANGE AGITATOR BASE

OVERALL DIMENSIONS					
FLANGE	A	B	C	n°	M
DN50	165	128	13	4x90°	40