

**LMDS**

## Lateral agitators



INOXMIM has designed LMDS side agitators with a compact size and a configuration which allows vessels with small and medium volumes to be homogenised. The simplicity of the parts, along with the mechanical sealing system, allows these agitators to achieve optimum mixing in a large variety of applications. For these reasons, LMDS are economical, high-performance agitators.

LMDS lateral agitators are used in the food, cosmetics, chemical, pharmaceutical and water treatment industry. Some examples of applications are:

- Agitating and homogenising mixes
- Maintaining products/reagents
- Homogenisation of the mix for heat exchange
- Heavy particle suspension

### MODELS

**LMDS 0.25**  
**LMDS 0.37**  
**LMDS 0.55**  
**LMDS 0.75**  
**LMDS 0.37 R**

### CHARACTERISTICS

DN50 DIN 2576 Anchor flange  
 Direct motor and geared motor  
 Single mechanical seal C/C/N  
 Interchangeability of agitator components  
 Easy assembly/dismounting  
 Simplicity of parts

### MATERIALS

Parts in contact with the product in stainless steel AISI 316  
 Parts not in contact with the product in stainless steel AISI 304, carbon steel and others

### OPTIONS

Control panel  
 Double mechanical seal  
 Speed variator  
 Other materials  
 Motor cover

## DIMENSIONS OF THE LMDS MODEL

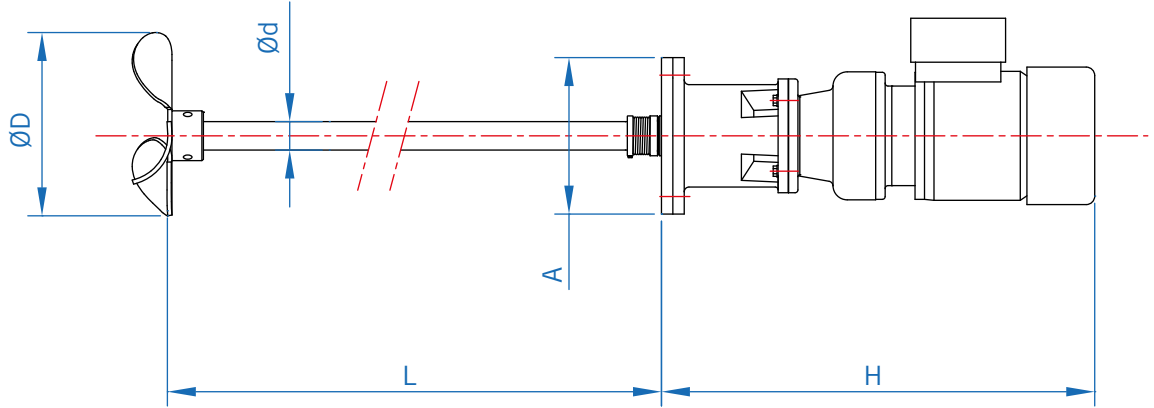
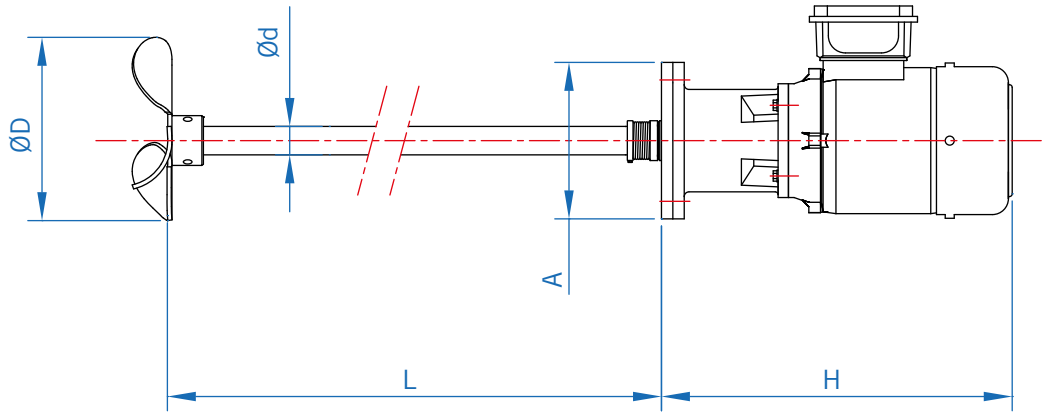

### AGITATOR BASE

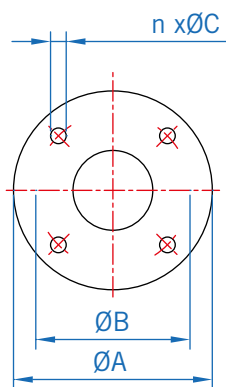

FLANGE	OVERALL DIMENSIONS							WEIGHT	
	A	B	C	n°	d	D	L	H	Kg
<b>DN50</b>	165	128	13	4x90°	25	110-250	450	340-520	17 - 24.5