

GFL

Vertical agitator

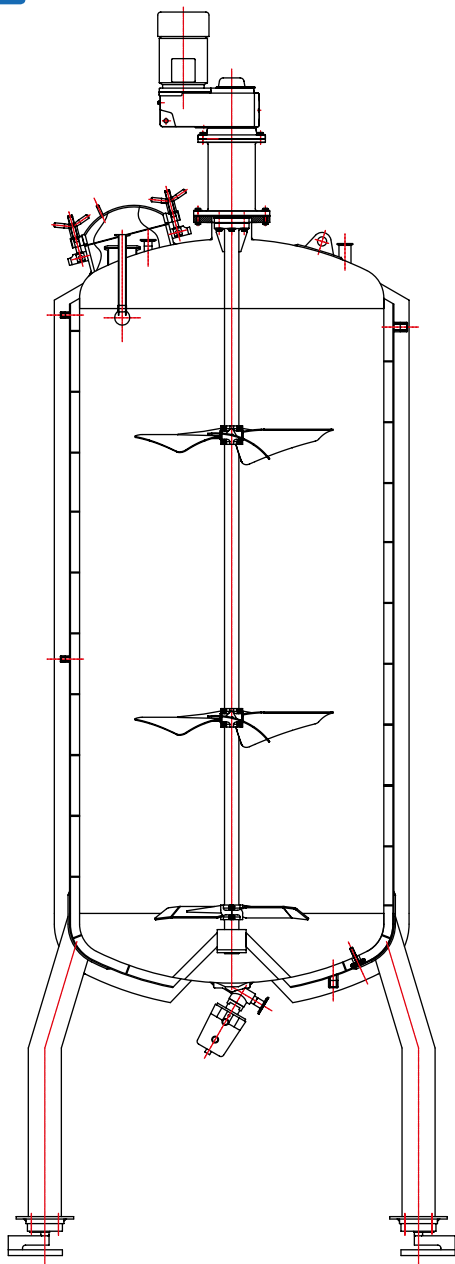

GFL vertical agitators, driven by a parallel geared motor, work at low turning speeds, allowing the use of agitator elements with a large surface area in order to achieve high work performance.

These agitators are characterised by their wide range of applications and high agitating capacity. This is achieved through the multiple configurations of the impellers, which also means GFL agitators can adapt to the requirements of each system. As a result, they are essential in the food, cosmetics, pharmaceutical and chemical industries.

In the food sector they can be used in the preparation of dairy desserts, manufacture of cream for distilled drinks, juices, gazpacho, chocolate, etc.

In the chemical sector they are used to agitate and homogenise medium and large volume vessels.

The most common applications in the pharmaceutical industry are: homogenisation, temperature exchange,

mixes and suspensions for products in tablets, solutions or creams.

In the cosmetics industry these agitators are used to manufacture gel, soap, eau de cologne, etc. They are also used in homogenisations, heat exchange, mixes and suspensions.

The different configurations used are:

- One or several vane levels
- Combination of different types of impellers
- Lower anchor with tripod guide
- Top anchor with turret
- Semi-shaft in flange plate and shaft in multiple parts
- Agitator in reverse assembly position and quick coupling

DIMENSIONS AND CHARACTERISTICS OF THE GFL MODEL

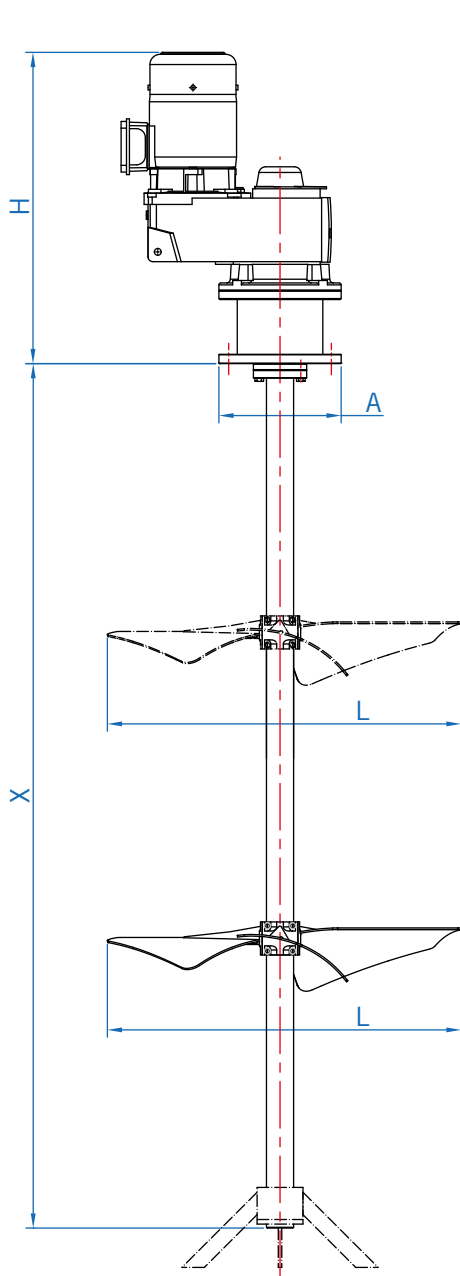

IEC FLANGE AGITATOR BASE

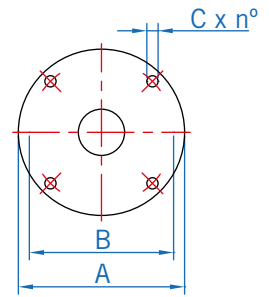

OVERALL DIMENSIONS				
FLANGE	A	B	C	n°
IEC 160	160	130	9	4x90°
IEC 200	200	165	11	4x90°
IEC 250	250	215	14	4x90°
IEC 300	300	265	14	4x90°
IEC 350	350	300	18	4x90°

DIN 2576 PN10 FLANGE AGITATOR BASE

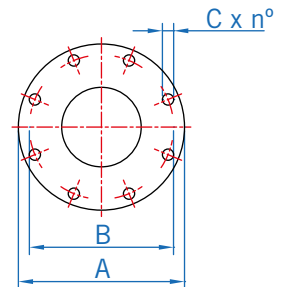

OVERALL DIMENSIONS				
FLANGE	A	B	C	n°
DN80	200	160	18	8x45°
DN125	250	210	18	8x45°
DN150	285	240	18	8x45°
DN200	340	295	18	8x45°
DN250	395	350	22	12x30°
DN300	445	400	22	12x30°

CHARACTERISTICS

- Level of finish: Industrial / Foodstuff / Sanitary
- Anchor flange: Square / DIN 2576 / IEC type
- Parallel geared motor
- Interchangeability of agitator components
- Single mechanical seal

MATERIALS

- Parts in contact with the product in stainless steel AISI 316L
- Parts not in contact with the product in stainless steel AISI 304L, carbon steel and others

OPTIONS

- Other materials: AISI 304L, AISI 904L, Hastelloy, etc.
- Mechanical seal: dual, cooled
- Bolstering tower
- Other anchor flanges
- Tripod guides
- Control panel
- Speed variator
- Casing

SQUARE PLATE FLANGE AGITATOR BASE

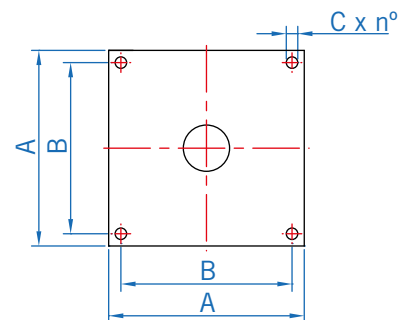

OVERALL DIMENSIONS				
FLANGE	A	B	C	n°
250 x 250	250	200	18	4
300 x 300	300	250	18	4
400 x 400	400	350	18	4
450 x 450	450	400	22	4
500 x 500	500	450	22	4