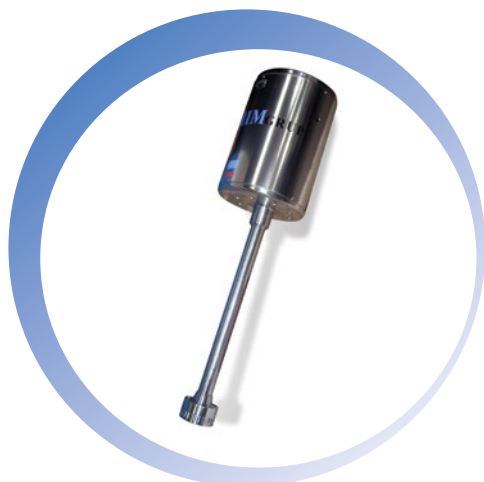

EMV
Mixer

EMV --- 1 stage and EMVT --- 2 stages mixers have been designed to obtain emulsions and dispersions which require a high degree of shearing. The functions of these systems mean they can work with high viscosity products (up to 20,000 cP) and obtain a completely homogenous result.

The sealing system allows work to be carried out in non-atmospheric conditions (overpressure and/or vacuum) without using a cooled external mechanical seal. The design of the headpiece and the rotor ensures a high degree of sanitisation which, together with the simplicity of the parts, makes maintenance easier.

EMVT --- mixers have been developed for products which are difficult to mix, since the headpiece design adapts to each application, improving performance and optimising operating time.

WORKING PRINCIPLE

The rotation of the impeller generates a radial impulsion of the product towards the headpiece slots, resulting in shearing and crushing. Once the product passes the stator orifices, it is projected and dispersed towards the mix, resulting in fluid circulation inside the vessel. Thus, as the product is dispersed, new material is introduced in the headpiece to produce a completely homogeneous mix.

It is important to emphasise that the circulation rate generated can dissolve large amounts of powder and is highly suitable for the chemical, food, cosmetics and pharmaceutical industries. Some of the EMV mixer applications are:

- Mixing of mayonnaise, creams, sauces, etc.
- Dissolving of sugars, salts, resins, gases, etc.
- Homogenisation of bulk containers (IBCs)
- Dissolving of powders, gums, thickeners, etc.

MODELS

- EMV(T) 0.55 – 50**
- EMV(T) 1.5 – 150**
- EMV(T) 2.2 – 250**
- EMV(T) 4 – 500**
- EMV(T) 7.5 – 1500**
- EMV(T) 11 – 2500**
- EMV(T) 18.5 – 7000**

CARACTERISTICS

- DIN 2576 Anchor flange
- IEC Motor flange
- Adjustable headpiece and turbine design
- Easy assembly/dismounting
- Single mechanical seal
- High degree of hygiene

MATERIALS

The parts in contact with the product are made from AISI 316L

OPTIONS

- Control panel
- Frequency variator
- Manual/automatic elevation system
- Other connections
- Other materials: Hastelloy, AISI 904L, etc.
- Motor cover

DIN 2576 FLANGE MIXER BASE

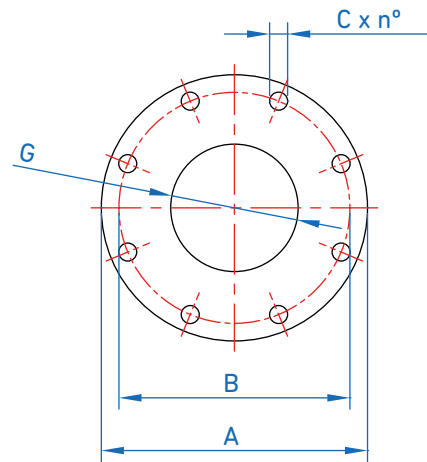
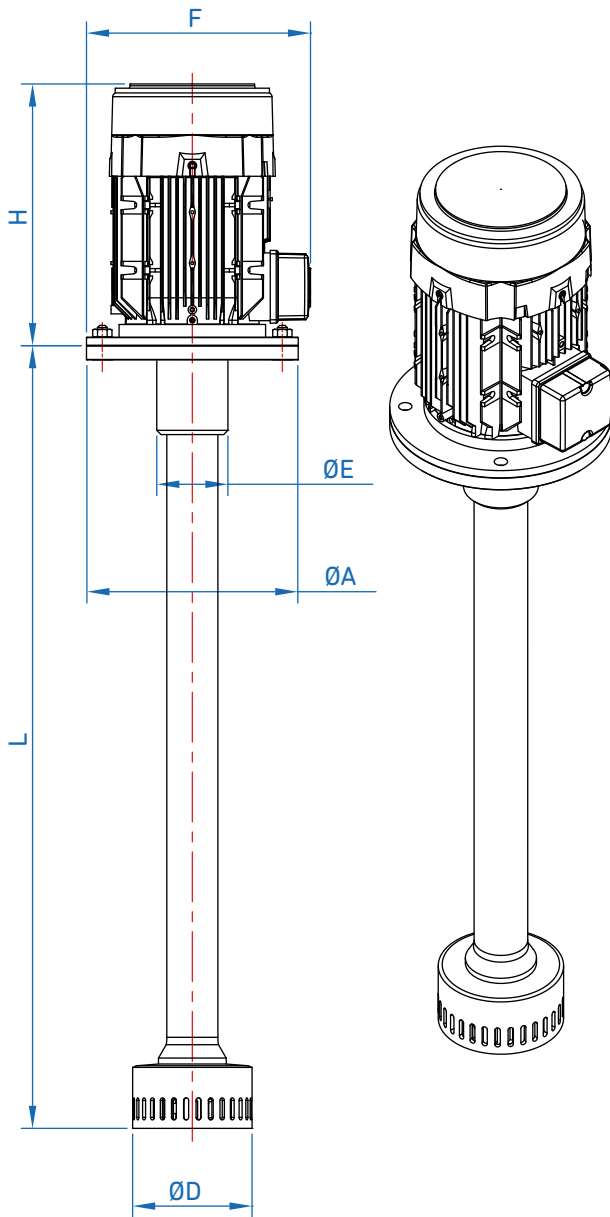

OVERALL DIMENSIONS						
MODEL	A	B	C	n°	G	
EMV 0.55-50	DN50	Ø165	125	18	4x90°	61
EMV 1.5-150	DN80	Ø200	160	18	8x45°	90
EMV 2.2-250	DN80	Ø200	160	18	8x45°	90
EMV 4-500	DN150	Ø285	240	22	8x45°	170
EMV 7.5-1500	DN200	Ø340	295	22	8x45°	221
EMV 11-2500	DN250	Ø395	350	22	12x30°	276
EMV 18.5-10000	DN300	Ø445	400	22	12x30°	260

IEC FLANGE MIXER BASE

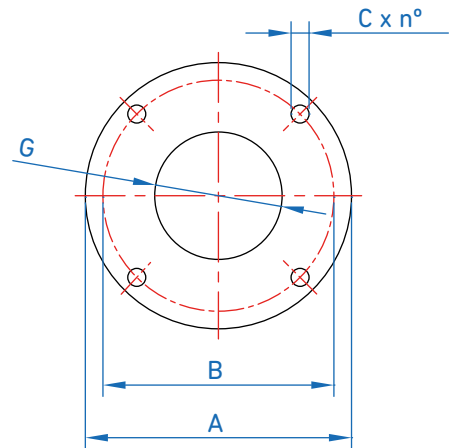

OVERALL DIMENSIONS						
MODEL	P (kW)	H	F	ØE	ØD	L
EMV 0.55-50	0.55	210	192	50	60	500
EMV 1.5-150	1.5	260	227	84	89	650
EMV 2.2-250	2.2	260	227	84	115	650
EMV 4-500	4	333	280	84	141	800
EMV 7.5-1500	7.5	470	359	120	168	1000
EMV 11-2500	11	474	408	160	205	1200
EMV 18.5-10000	18.5	474	433	200	220	1400

OVERALL DIMENSIONS						
MODEL	A	B	C	n°	G	
EMV 0.55-50	IEC 160	160	130	9	4x90°	110
EMV 1.5-150	IEC 200	200	165	11	4x90°	130
EMV 2.2-250	IEC 200	200	165	11	4x90°	130
EMV 4-500	IEC 250	250	215	14	4x90°	180
EMV 7.5-1500	IEC 300	300	265	14	4x90°	230
EMV 11-2500	IEC 300	300	265	14	4x90°	230
EMV 18.5-10000	IEC 350	350	300	18	4x90°	250