

Tekno-Hygienic | Solid Vulcanized Bolt/Down Base | Ø 150

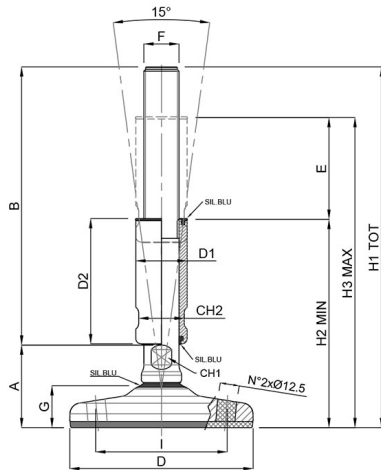

CODE	SIZE (F)	FLOOR DISTANCE (A)	STEM LENGTH (B)	BASE SIZE (D)	BUSHING Ø (D1)	TOTAL HEIGHT (D2)	HOLES DISTANCE (E)	MIN HEIGHT (H2)	MAX HEIGHT (H3)	REGULATION (SW)	WEIGHT gr	LOAD (Newton)
27411F/3A	M20x2,5	59	140,00	150	30x60	199,00	110	120	165	17/26	2629	45000
27413F/3A	M20x2,5	59	190,00	150	30x85	249,00	110	145	215	17/26	2807	45000
27415F/3A	M24x3	59	140,00	150	35x60	199,00	110	120	165	20/30	2835	60000
27417F/3A	M24x3	59	190,00	150	35x85	249,00	110	145	215	20/30	3089	60000
27419F/3A	M30x3,5	59	135,00	150	42x60	194,00	110	120	160	26/36	3183	80000
27421F/3A	M30x3,5	59	185,00	150	42x85	244,00	110	145	210	26/36	3551	80000
27423F/3A	M30x3,5	59	235,00	150	42x85	294,00	110	195	260	26/36	3828	80000
27425F/3A	M36x4	59	135,00	150	50x60	194,00	110	120	160	32/45	3643	80000
27427F/3A	M36x4	59	185,00	150	50x85	244,00	110	145	210	32/45	4185	80000
27429F/3A	M36x4	59	235,00	150	50x85	294,00	110	195	260	32/45	4584	80000

- Levelling system designed for the dairy, pharmaceutical and food industry, in compliance with the strictest hygienic standards, made in accordance with 3-A regulations.