

Tekno-Hygienic | Solid Bolt/Down Base | Ø 150

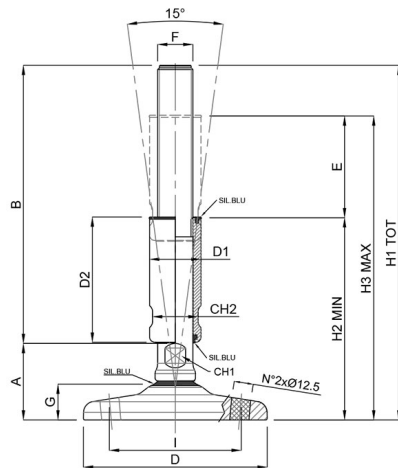

CODE	SIZE (F)	FLOOR DISTANCE (A)	STEM LENGTH (B)	BASE SIZE (D)	BUSHING Ø (D1)	TOTAL HEIGHT	MIN HEIGHT (H2)	MAX HEIGHT (H3)	HOLES DISTANCE (I)	REGULATIO N (SW)	WEIGHT gr	LOAD (Newton)
27410F/3A	M20x2,5	54	140,00	150	30x60	194,00	115	160	110	17/26	2519	45000
27412F/3A	M20x2,5	54	190,00	150	30x85	244,00	140	210	110	17/26	2713	45000
27414F/3A	M24x3	54	140,00	150	35x60	194,00	115	160	110	20/30	2719	55000
27416F/3A	M24x3	54	190,00	150	35x85	244,00	140	210	110	20/30	2970	55000
27418F/3A	M30x3,5	54	135,00	150	42x60	189,00	115	155	110	26/36	3066	60000
27420F/3A	M30x3,5	54	185,00	150	42x85	239,00	140	205	110	26/36	3438	60000
27422F/3A	M30x3,5	54	235,00	150	42x85	289,00	190	255	110	26/36	3717	60000
27424F/3A	M36x4	54	135,00	150	50x60	189,00	115	155	110	32/45	3530	80000
27426F/3A	M36x4	54	185,00	150	50x85	239,00	140	205	110	32/45	4080	80000
27428F/3A	M36x4	54	235,00	150	50x85	289,00	190	255	110	32/45	4478	80000

- Levelling system designed for the dairy, pharmaceutical and food industry, in compliance with the strictest hygienic standards, made in accordance with 3-A regulations.