

## Tekno-Hygienic | Solid Bolt/Down Base | Ø 100/120

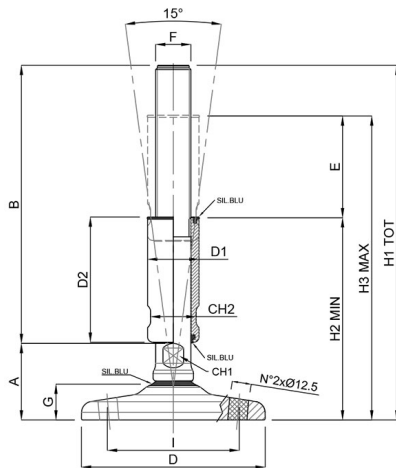

CODE	SIZE (F)	FLOOR DISTANCE (A)	STEM LENGTH (B)	BASE SIZE (D)	BUSHING Ø (D1)	TOTAL HEIGHT	MIN HEIGHT (H2)	MAX HEIGHT (H3)	HOLES DISTANCE (I)	REGULATIO N (SW)	WEIGHT gr	LOAD (Newton)
27360F/3A	M16x2	49	140,00	100	24x60	189,00	110	155	70	13/20	997	40000
27362F/3A	M16x2	49	190,00	100	24x85	239,00	135	205	70	13/20	1117	40000
27364F/3A	M20x2,5	49	140,00	100	30x60	189,00	110	155	70	17/26	1191	45000
27366F/3A	M20x2,5	49	190,00	100	30x85	239,00	135	205	70	17/26	1371	45000
27368F/3A	M24x3	49	140,00	100	35x60	189,00	110	155	70	20/30	1389	55000
27370F/3A	M24x3	49	190,00	100	35x85	239,00	135	205	70	20/30	1639	55000
27372F/3A	M30x3,5	49	135,00	100	42x60	184,00	110	150	70	26/36	1731	60000
27374F/3A	M30x3,5	49	185,00	100	42x85	234,00	135	200	70	26/36	2108	60000
27380F/3A	M16x2	51	140,00	120	24x60	191,00	112	157	86	13/20	1507	40000
27382F/3A	M16x2	51	190,00	120	24x85	241,00	137	207	86	13/20	1623	40000
27384F/3A	M20x2,5	51	140,00	120	30x60	191,00	112	157	86	17/26	1700	45000
27386F/3A	M20x2,5	51	190,00	120	30x85	241,00	137	207	86	17/26	1879	45000
27388F/3A	M24x3	51	140,00	120	35x60	191,00	112	157	86	20/30	1895	55000
27390F/3A	M24x3	51	190,00	120	35x85	241,00	137	207	86	20/30	2149	55000
27392F/3A	M30x3,5	51	135,00	120	42x60	186,00	112	152	86	26/36	2243	60000
27394F/3A	M30x3,5	51	185,00	120	42x85	236,00	137	202	86	26/36	2618	60000
27396F/3A	M30x3,5	51	235,00	120	42x85	286,00	187	252	86	26/36	2898	60000
27398F/3A	M36x4	51	135,00	120	50x60	186,00	112	152	86	32/45	2711	80000
27400F/3A	M36x4	51	185,00	120	50x85	236,00	137	202	86	32/45	3259	80000
27402F/3A	M36x4	51	235,00	120	50x85	286,00	187	252	86	32/45	3658	80000

- Levelling system designed for the dairy, pharmaceutical and food industry, in compliance with the strictest hygienic standards, made in accordance with 3-A regulations.