

Tekno-Hygienic | Solid Base | Ø 60/80/100

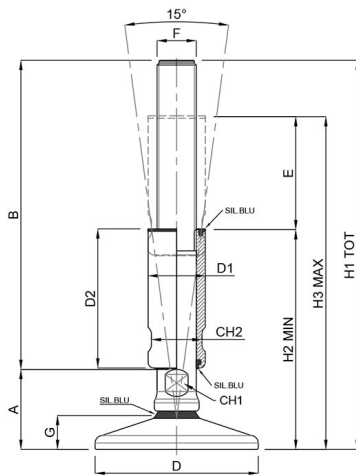

CODE	SIZE (F)	FLOOR DISTANCE (A)	STEM LENGTH (B)	BASE SIZE (D)	BUSHING Ø (D1)	TOTAL HEIGHT	MIN HEIGHT (H2)	MAX HEIGHT (H3)	REGULATION (SW)	WEIGHT gr	LOAD (Newton)
27320/3A	M12x1,75	45	140,00	60	24x60	185,00	106	151	13/20	546	25000
27322/3A	M12x1,75	45	190,00	60	24x85	235,00	131	201	13/20	641	25000
27324/3A	M16x2	45	140,00	60	24x60	185,00	106	151	13/20	586	40000
27326/3A	M16x2	45	190,00	60	24x85	235,00	131	201	13/20	700	40000
27328/3A	M20x2,5	45	140,00	60	30x60	185,00	106	151	17/26	765	45000
27330/3A	M20x2,5	45	190,00	60	30x85	235,00	131	201	17/26	951	45000
27340/3A	M16x2	47	140,00	80	24x60	187,00	108	153	13/20	796	40000
27342/3A	M16x2	47	190,00	80	24x85	237,00	133	203	13/20	914	40000
27344/3A	M20x2,5	47	140,00	80	30x60	187,00	108	153	17/26	989	45000
27346/3A	M20x2,5	47	142,00	80	30x70	189,00	117	172	17/26	1021	45000
27348/3A	M20x2,5	47	190,00	80	30x85	237,00	133	203	17/26	1167	45000
27350/3A	M24x3	47	140,00	80	35x60	187,00	108	153	20/30	1188	50000
27352/3A	M24x3	47	190,00	80	35x85	237,00	133	203	20/30	1436	50000
27360/3A	M16x2	49	140,00	100	24x60	189,00	110	155	13/20	1106	40000
27362/3A	M16x2	49	190,00	100	24x85	239,00	135	205	13/20	1222	40000
27364/3A	M20x2,5	49	140,00	100	30x60	189,00	110	155	17/26	1298	45000
27366/3A	M20x2,5	49	190,00	100	30x85	239,00	135	205	17/26	1477	45000
27368/3A	M24x3	49	140,00	100	35x60	189,00	110	155	20/30	1494	55000
27370/3A	M24x3	49	190,00	100	35x85	239,00	135	205	20/30	1748	55000
27372/3A	M30x3,5	49	135,00	100	42x60	184,00	110	150	26/36	1836	60000
27374/3A	M30x3,5	49	185,00	100	42x85	234,00	135	200	26/36	2210	60000

• Levelling system designed for the dairy, pharmaceutical and food industry, in compliance with the strictest hygienic standards, made in accordance with 3-A regulations.