

## Optimising the hygienic design of pumps

Hygienic production conditions are an ever-topical issue in food and beverage processing and pharmaceutical manufacturing facilities. In the early 2000s, the EHEDG instituted detailed guidelines for pump manufacturers: Document 25 deals with the design of floating ring seals, and Document 17 (3rd edition) covers the design of pumps. In particular, the sealing concept for the area coming into contact with the product, the construction of the pump's interior (eliminating dead spaces and gaps), plus the material properties and installation conditions are fully detailed in the design stipulations.

By Willi Wiedenmann, Evoguard GmbH, Germany, e-mail: [willi.wiedenmann@evoguard.com](mailto:willi.wiedenmann@evoguard.com)

The pumps used in a production line, often in different model sizes, constitute a particularly comprehensive challenge for manufacturers, especially when they have to update components in order to meet newly enacted standards. Pump manufacturers also are confronted by the necessity of having to exhaustively review the suitability of the pump's components, and often revise the design stipulations previously applying. Alternatively, of course, they can opt for creating a completely new design. This was the approach that the designers at Evoguard GmbH adopted, who started off with a meticulous interpretation of the EHEDG's guidelines, and on this basis developed their new series of pumps.

Besides the hygienic aspects, the criteria for the new design concept included:

- Improved efficiency
- Providing the requisite range of ratings for a pump family with full applicational coverage
- Good accessibility and maintenance-friendliness, plus error minimisation for maintenance work
- High energy-efficiency

### Basic pump construction – the foundation for hygienic design

The first item to consider when designing hygienic pumps is the construction materials. For the areas that will come into contact with the product, the material chosen for the series of pumps is AISI 316L ( $Ra \leq 0.8 \mu$  at the housing and as standard  $Ra \leq 0.8 \mu$  at the impeller), while AISI 304 is used for the areas that do not come into contact with the product. The pump components are manufactured from solid material (e.g., impeller, housing and cover) to offer optimum preconditions for hygienic applications in terms of design and cleanability. Metal centering devices flush against the components to ensure sealing efficacy to meet the stipulations mandated by the EHEDG. A special guide contour in the housing allows for optimised hydraulic efficiency. The tangential removal of the product supports its gentle and flow-optimised routing. The impeller (also made of solid material) integrates fuming bars, and thus manages without any pressure relief boreholes for equalising the pressure differentials between the front and rear. The five-blade design ensures low impeller friction losses, which at the same time also helps to reduce noise emissions during operation.

One design enhancement helps during assembly, dismantling and adjustment of the gap dimension without the need for any special tools: the motor shaft is connected to the impeller by a hydraulic clamping set with just one screw in a self-centering design. This ensures fast assembly, dismantling and adjustment of the clearance between the impeller and the housing (Figure 1a-d). Upon request, the design can be equipped with a drain plug for the complete draining of the pump.

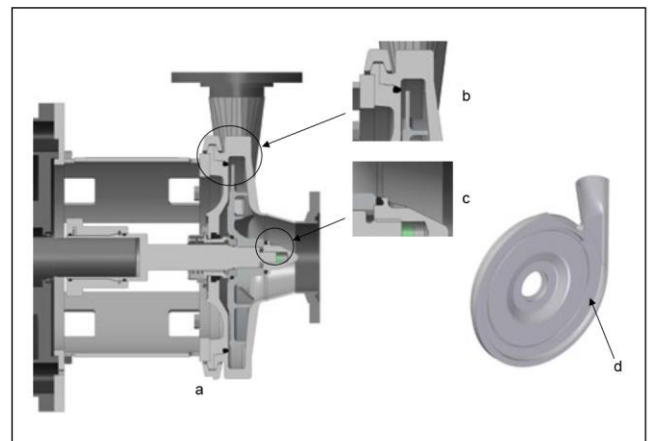

Figure 1a-d. (a) Cross-section through the pump; (b) and (c) seals at the housing, impeller and cover for complete draining in conformity with the EHEDG stipulations; and (d) optimised guiding contour in the housing, plus tangential removal of the product.

### Central element: floating ring seal

In the new design, the construction of the floating ring seal is a central element (Figure 2). The seal exhibits smooth surfaces throughout in the product compartment, and for the first time also integrates a gapless construction with a shaft seal designed in conformity with the US Food and Drug Administration's (FDA) criteria. The counter-ring features an "open" annular groove for optimum cleaning. The same idea has been incorporated in the design of the sliding surface near the impeller to ensure continuous cooling and optimal cleanability.

Wear and tear on the pump shaft is avoided by keeping the floating ring stationary in the cover without contact with the shaft. With an additional anti-torsion system in the cover, the positioning is secured on a lasting basis. One of the paramount stipulations contained in the EHEDG documents

is the configuration of springs and entraining elements outside the product compartment. This has been addressed in the new pump design by separate chambering of the springs outside the flow-channeling compartment (Figure 3).

The useful lifetime of the floating ring seal has also been extended by the new design. The pressure conditions at the floating ring seal are in the overpressure range. With the stationary positioning of the floating ring in the cover, the material remains free from wear-and-tear phenomena. If, despite these precautionary measures, defects occur, then a large gap offers fast and reliable detection methods, particularly in the case of viscous media such as syrup.

Thanks to the modularised construction, the floating rings, counter-rings and the elastomer seals can be individually replaced without having to separate the pump from the motor. Simple assembly has been designed into the motor, as with the floating ring seal, which can be quickly dismantled into its individual parts; here, too – as with the valves – the risk of confusing components during assembly has been eliminated.



Figure 2. The design of the axial face seal in detail.

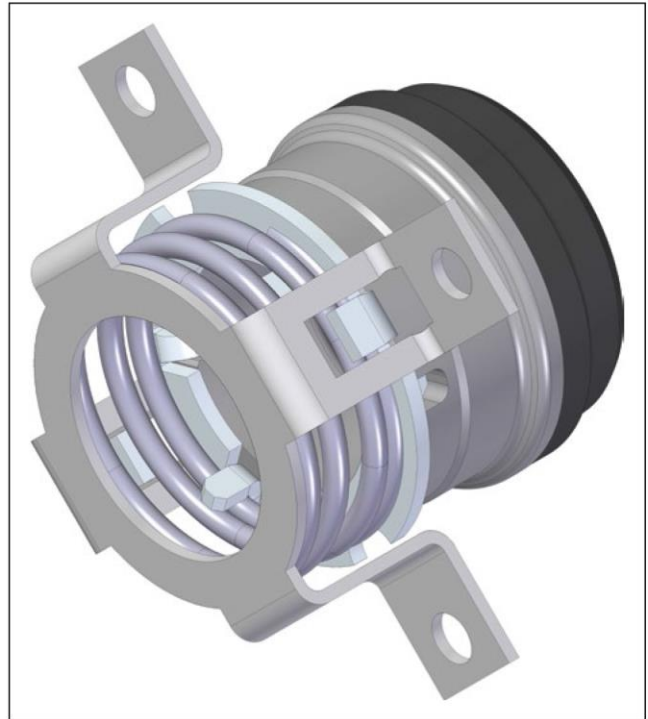

Figure 3. Positioning of the spring outside the flushing medium.

### Optimally reliable product delivery

Besides the principal task of creating an EHEDG-compliant design, product-specific aspects were also taken into account when designing this new series of pumps. With different blade heights and impeller diameters, the most suitable pump for each particular application can be dimensioned to suit the product characteristics involved and thus ensure gentle, even product delivery. The standard single-acting floating ring seal can be replaced by a double-acting variant, so that these pumps can be used in aseptic systems featuring a barrier medium.